

Verification Gage

for Denar® Mark 300 Series
Articulators

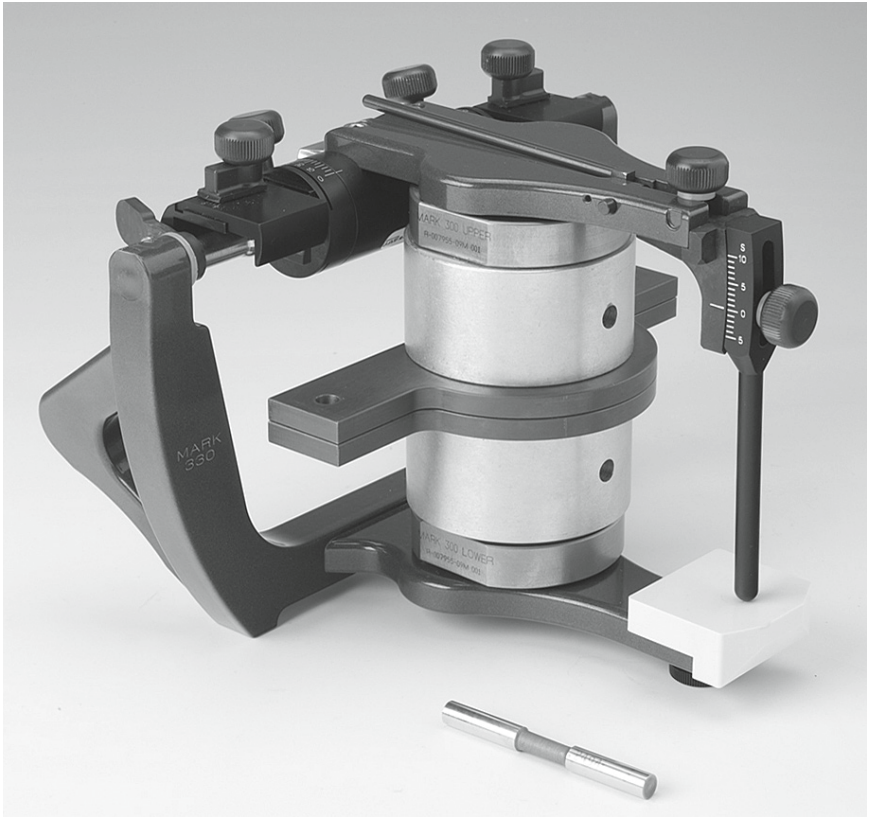

Instruction Manual
Item No. 20011660



RESTORATIVE ORAL HEALTH

Table of Contents

Introduction 3

Step 1: Cleaning Surfaces 4

Step 2: Mounting the Gage 4

Step 3: Verification Process 4

Step 4: Cleaning the Fossae 5

Step 5: Checking the Fossae 5

Introduction

The purpose of this verification gage is to give you a way to check the calibration of your Mark 300 series articulator in your office or lab. The Mark 300 series articulators are factory set to within 20 microns of accuracy.

Components:

- Upper Verification Gage
 - Lower Verification Gage
 - Verification Pin
- (Figure 1)



Figure 1

Important Note:

Each Verification Gage pair is marked with a serial number. It is vital that the upper and lower gages match, otherwise the results may not be accurate. (Figure 2)



Figure 2

Step 1: Cleaning Surfaces

Unlatch and remove the upper member. Loosen the incisal pin and raise it up to around -5, with the goal being just to move the pin out of the way. (Figure 3)

Using a q-tip and alcohol, clean the mounting surfaces of the upper and lower members of your articulator, and both mounting surfaces of your gage. If you have an air nozzle, use it to blow dry all surfaces. Do make sure the air nozzle is not blowing particles on to your surfaces.

With tolerances of 20 micron, any particles left on these surfaces will affect the accuracy of the verification.

Step 2: Mounting the Gage

Mount the upper and lower gage blocks to the upper and lower members locating on the back dimples. The magnet is very strong, and if you slide the gage into place, you may scratch the surface. (Figure 4)

Attach the upper member of the articulator to the lower member, and push the latch down to lock into place. Make sure that the instrument settings are zero before beginning the verification.

Step 3: Verification Process

The first step is to check for gap around the 3" diameter of your gage. Using 20 micron mylar, slide it between the upper and lower gage and close the gage. Pulling on the mylar, you should feel a slight to tight drag. Check this four times at the 1 o'clock, 5 o'clock, 7 o'clock, and 11 o'clock positions. If the mylar pulls right out, write down what happened and continue with this process. We will check this again at a later stage. (Figure 5)

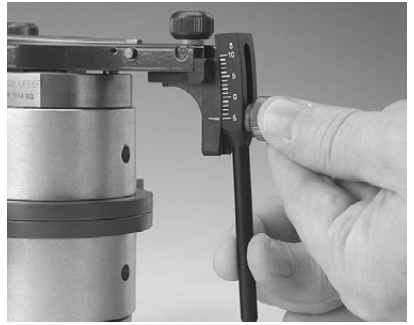

Figure 3

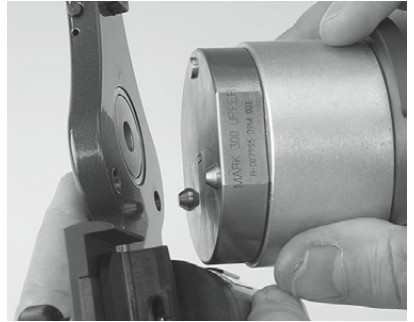

Figure 4

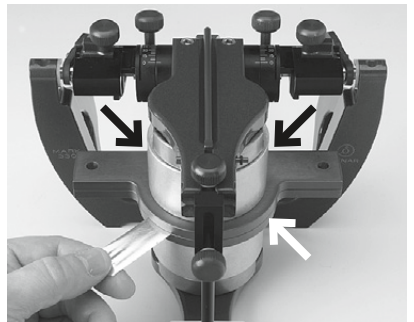

Figure 5

The verification pin will be used to slide through the holes on each side of the gage. Set the pin on one of the holes. The pin will slide all the way through the hole on its own if the articulator is in calibration. If the pin doesn't fall immediately, it may be caught on the lip of the gage. Wiggle the pin side to side slightly to see if the pin will fall. **Do not push down on the pin.** If you have to force the pin through the hole on either side of the gage, the articulator is out of calibration. (Figure 6)

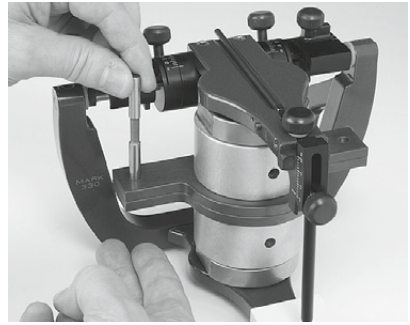

Figure 6

If the gap check is ok, and the verification pin falls easily on both sides, your instrument is in calibration. (Figure 7) Remove the gage. With the upper and lower members together and the instrument locked, drop the incisal pin to sit on the guide table. The pin should be lined up at the zero mark.

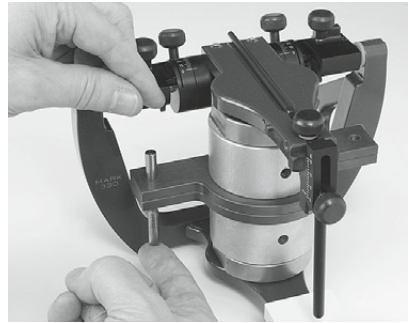

Figure 7

If your instrument is not in calibration, follow the next steps to see what may be causing the problem.

Step 4: Cleaning the Fossae

The fossae may be causing the articulator to be out of calibration due to wear of the medial insert or dirt particles.

Unlock and remove the upper member. Check to see if there are dirt particles on either fossa, and clean if necessary. Repeat the above verification process. (Figure 8)

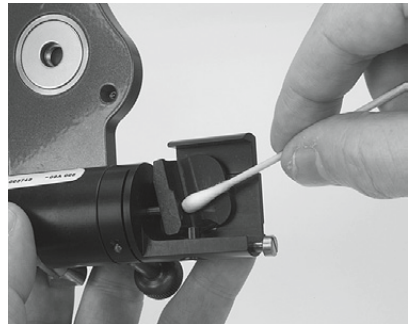

Figure 8

If during your check for gap the mylar continues to pull right out (no resistance), this instrument will need to be sent to the factory for repair.

Step 5: Checking the Fossae

If the articulator is still out of calibration after using the verification pin in step 4, remove the fossae and repeat the verification process without the fossae as follows.

Unlock and remove the upper member. Loosen both fossae lock knobs and remove both fossae. Then set the upper

gage block on top of the lower gage block. Push the latch down to lock the upper and lower members into place. Go through the pin verification process mentioned in step 3. If the pin now drops easily through each hole, the issue is with one or both of the fossae. (Figure 9)

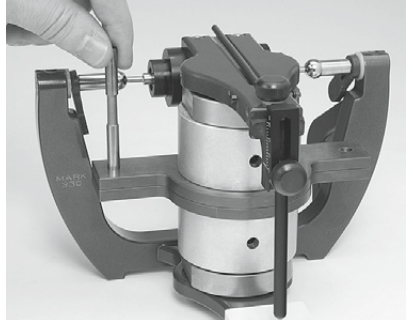

Figure 9

Replace one of the fossae on to the upper member and tighten with the fossae lock knob. Place the upper gage block on top of the lower gage block. Push the latch down to lock the upper and lower members into place. Go through the pin verification process mentioned in step 3. If the pin now drops easily through each hole, this fossa is not causing the problem. (Figure 10)

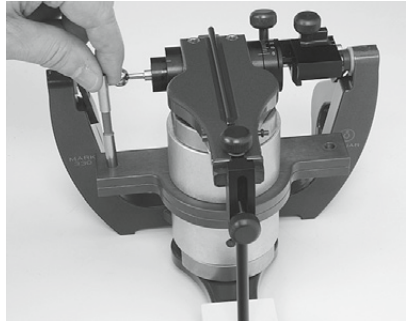

Figure 10

Put both fossae back on the upper member, lock into place, and once again repeat the pin verification process. **If both pins do not drop easily, write down which fossa appears to be causing the problem. This instrument will then need to be sent into the factory for repair.**

To return for repair, call (800) 626-5651
Once you have an RMA number, return to:
Whip Mix Corporation
1730 E. Prospect Rd., Ste 101
Fort Collins, CO 80525



RESTORATIVE ORAL HEALTH

Whip Mix Corporation
361 Farmington Avenue
Louisville, KY USA 40209
Toll-Free: 800-626-5651
Fax: 502-634-4512

www.whipmix.com

*All trademarks identified with a TM or [®] are
trademarks of Whip Mix Corporation.
© 2010 Whip Mix Corporation.*